

# GM25-25BY

25mm gearbox plus 25mm stepper motor

Module	0.20		
Rated torque (kg.cm)	0.5 kg.cm max		
Max momentary tolerance torque (kg.cm)	1.0 kg.cm max		
Reduction ratio	1/10	1/30	1/60、1/75、1/100
Number of gear stages	2	3	4
Gearbox length L (mm)	11.0		

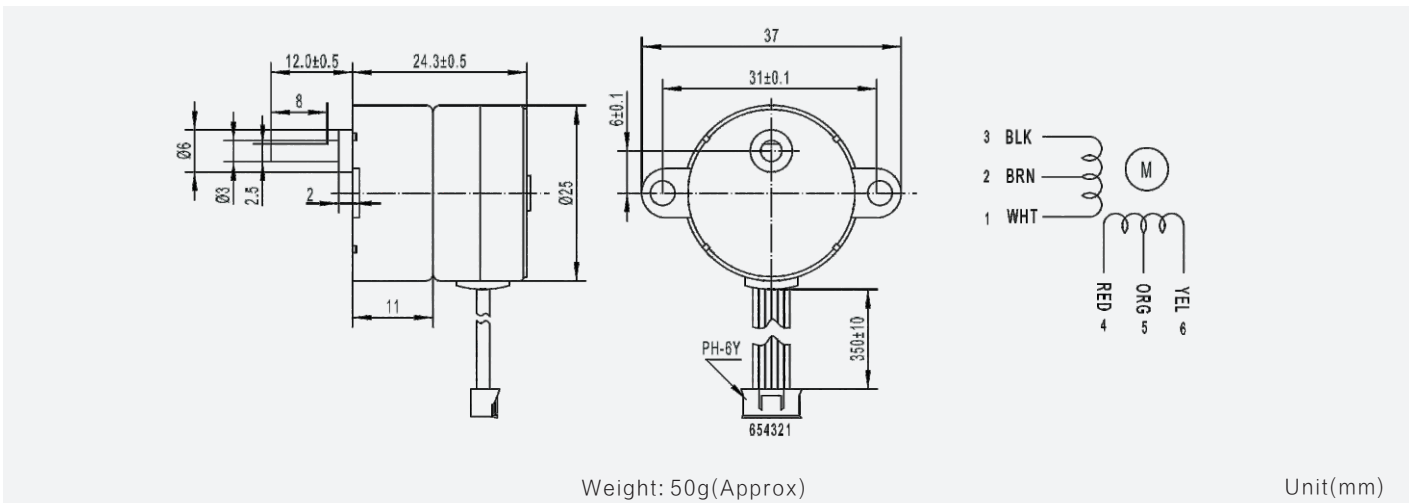

## Motor Technical Data

Motor model	Rated voltage	No. of phase	Step angle	Resistance	Current	Inductance	Detent torque	Holding torque	Pull in rate
	VDC			Ω	mA	mH	g.cm	g.cm	pps
<b>TS-25BY-001</b>	12.0	4	7.5°	100	120	14	15	100	600

