

User's Manual
For
ISD02/04/08
Integrated Stepper Motor Driver



Table of Contents

1. Introductions and Features.....	1
1.1 Introductions.....	1
1.2 Features.....	1
2. Specifications.....	1
2.1 Electrical Specifications (Tj = 25°C/77°F).....	1
2.2 Operating Environment and other Specifications.....	1
2.3 Mechanical Specifications.....	2
3. Pin Assignment and Description.....	2
3.1 Connector P1 Configurations.....	3
3.2 Connector P2 Configurations.....	3
4. Typical application.....	3
5. Interface.....	4
5.1 Adjust Output Current.....	4
5.2 Microstep Resolution.....	5
5.3 Power Supply Selection.....	5
6. Installation.....	6
6.1 NEMA 17 Stepper Installation (without adapting flange).....	6
6.2 NEMA 23 and Larger Stepper Installation (with adapting flange).....	6

1. Introductions and Features

1.1 Introductions

The ISD02/04/08 is a parallel port control series of miniature high performance stepper motor drivers. Its biggest feature is its small size and strong driving ability. Its thickness is less than 14 mm. They can be directly mounted onto NEMA 8/11/14/17/23/24/34 series stepper motors with the corresponding flange. ISD02 can provide 0-2A adjustable peak current; ISD04 can provide 1.5-4A adjustable peak current; ISD08 can provide 3-8A adjustable peak current. Its high-speed current compensation function can compensate for the effects of back electromotive force when the motor rotates at high speed. The ISD02 uses 10-28V DC power supply, and the ISD04 and the ISD08 use 10-40V DC power supply.

1.2 Features

- Miniature size 42.3mm*42.3mm*16.5mm
- Integrated with the motor, can also work separately
- All-aluminum precision cast housing, sturdy and durable, good heat dissipation
- Wide range input voltage
- 0 - 2A / 1.5 - 4A / 3 - 8A adjustable output current (ISD02/ISD04/ISD08)
- 5 selectable microstep solutions including 100, 200, 400, 800, 1600
- H-bridge bipolar constant current, online controllable offline / enable
- Optical-isolated inputs
- Automatic Current Reduction
- Maximum frequency of whole step 12KHz; Maximum frequency of 3200 microstep 200KHz

2. Specifications

2.1 Electrical Specifications (Tj = 25°C/77°F)

Supply Power	10-40VDC(10-28VDC for ISD02)
Motor Output Current	Max 2A/4A/8A per phase (Adjustable through on-board trimmer)
Driving Mode	PWM constant current
Microstep Resolution	100, 200, 400, 800, 1600 set through on-board DIP switch 1 and switch 2
Insulation Resistance	>100MΩ
Dielectric Strength	0.5KV in one minute

2.2 Operating Environment and other Specifications

Cooling	Free air
Working Environment	Avoid dust, oil fog and corrosive gases
Working	-40°C - 85°C
Humidity	<80%RH, no condensation, no frosting
Vibration	3G Max
Storage temperature	-50°C - 150°C

Weight	0.1kg
--------	-------

2.3 Mechanical Specifications (Unit: mm)

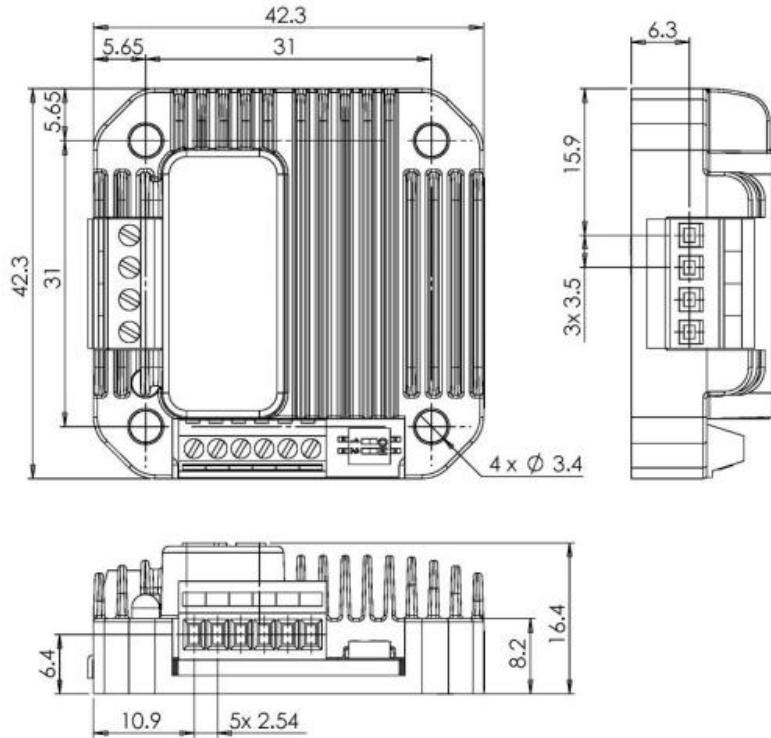

Figure 1: Mechanical specifications

3. Pin Assignment and Description

The ISD02/04/08 has two connectors P1&P2, P1 is for control signals connections, and P2 is for motor connections. The following tables are brief descriptions of the two connectors.

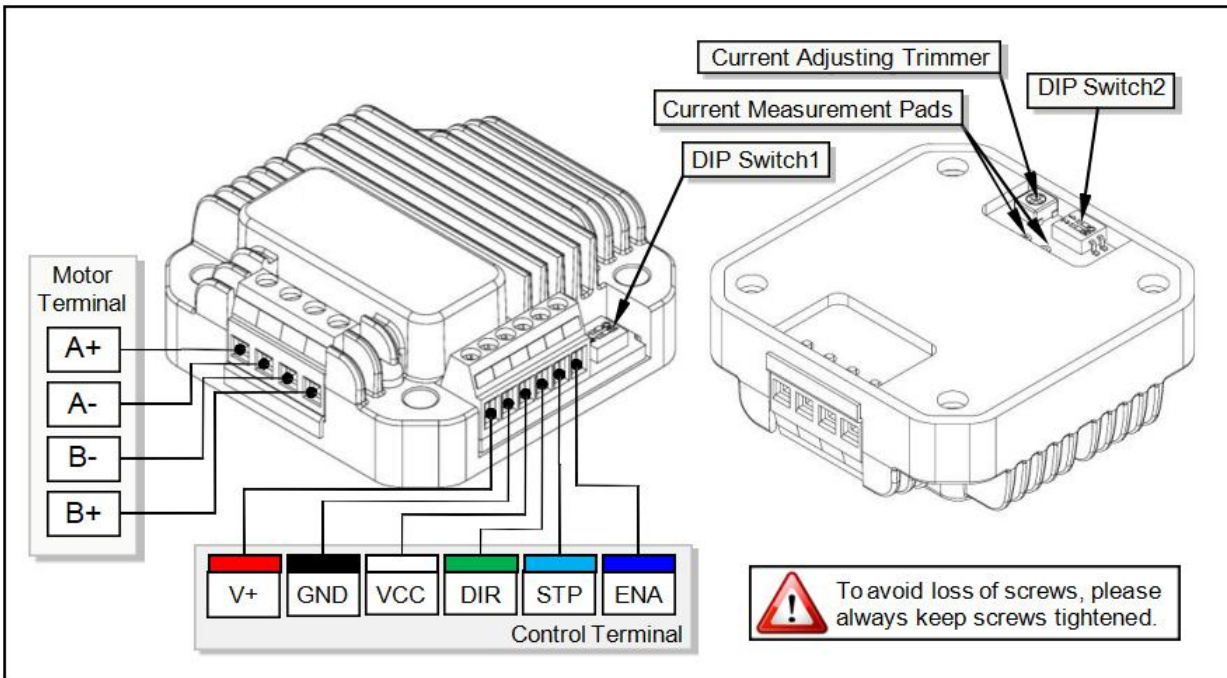

Figure 2:wiring terminal

3.1 Connector P1 Configurations

Pin Function	Description
V+	Supply voltage. ISD02:10-28VDC, ISD04 And ISD08:10-40VDC.
GND	Supply voltage ground
VCC	Opto-coupler common anode
DIR	Direction input ⁽¹⁾
STP	Stepping pulse input ⁽²⁾
ENA	Enable the controller ⁽³⁾

Note:

- (1) Input is considered high level if this terminal is not connected.
- (2) Low-level pulse duration should > 4 μ s.
- (3) An active low-level input shuts down power supply to the motor. High-level input or left open makes the controller fully working. When awoken from shutdown mode, wait 1 millisecond before sending pulse.

3.2 Connector P2 Configurations

Pin Function	Description
A+/A-	Connect to the stepper motor phase A.
B-/B+	Connect to the stepper motor phase B.



Warning: Incorrect connection of phase winds will permanently damage the driver.

Resistance between leads of different phases is usually > 100K Ω . Resistance between leads of the same phase is usually < 100 Ω .



Warning: In addition to the port of power supply and motor, the voltage of rest port must be in the range of -0.3V ~ 5.3V, otherwise it will permanently damage the controller.

4. Typical application

ISD02/04/08 driver's wiring is very straightforward as shown in following Figure. Terminal 6 (EN) can be left open if offline is not needed.

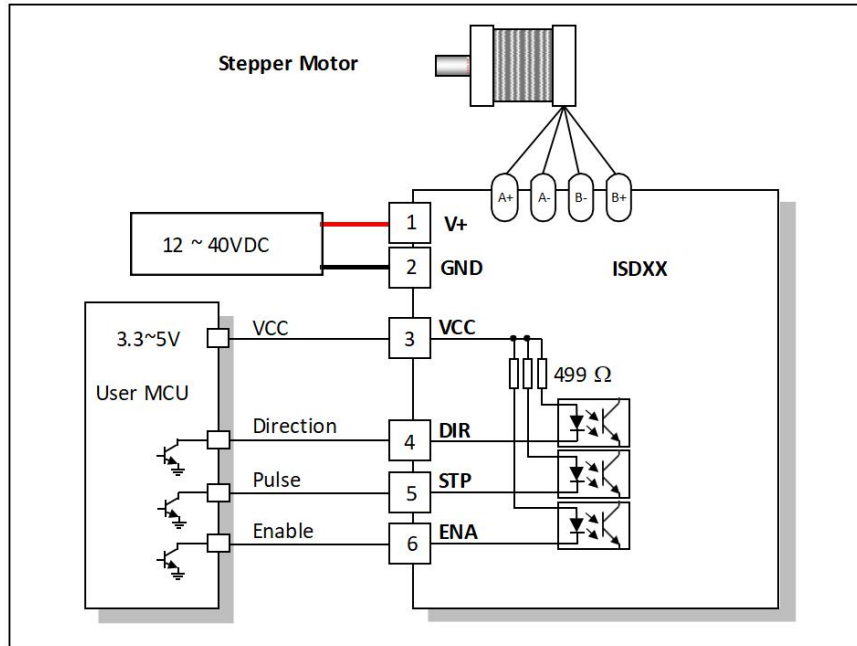

Figure 3: Typical application

5. Interface

ISD02/04/08 driver's logic control inputs are all optically isolated. All opto-isolators share one common anode (VCC) as shown in above schematic diagram. Typically, VCC is 5V. However, 3.3V or voltages higher than 5V are also acceptable, so long as the current through the opto-isolator's emitter is between 5~20mA.

Should a voltage higher than 5V be applied to VCC, an additional resistor is needed for every terminal to ensure that the current through each emitter does not exceed 20mA.

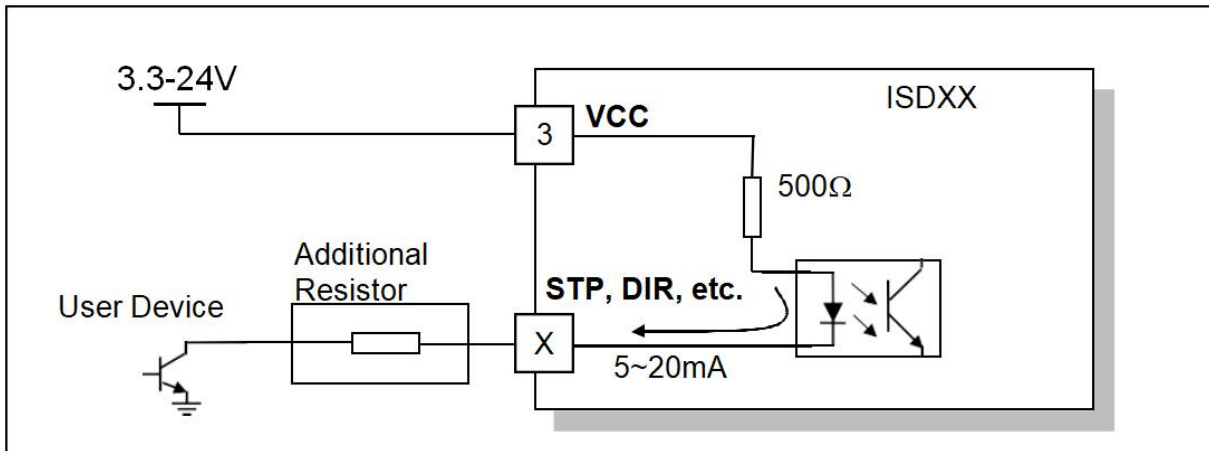

Figure 4: Optically Isolated Input Interface

Please note: in most situations, VCC can also be used as common cathode connection. This is because the opto-isolators used in ISD02/04/08 are bidirectional (AC&DC) type.

5.1 Adjust Output Current

ISD02/04/08 is capable of providing maximum 2A / 4A / 8A per phase output current respectively. In specific application, the peak output current needs to be adjusted to meet the rated motor current. A trimmer (potentiometer) is provided to serve this purpose at the bottom of the controller, as shown in the following figure. Measuring the mapped voltage (V_a) when tuning the trimmer provides a easy way to set

the output current.

For ISD02, a mapped voltage “Va” of 0 - 2V proportionally represents 0 - 2A.

For ISD04, a mapped voltage “Va” of 1.5 - 4V proportionally represents 1.5 - 4A.

For ISD08, a mapped voltage “Va” of 1.5 - 4V proportionally represents 3 - 8A.

Note:

The driver needs to be powered before mapped voltage “Va” can be measured. (Motor is not required to be connected at this time.)

DIP1 (on the bottom side DIP switch 2) needs to be turned off to shut down the ACR Function.

After adjustment, user can choose to turn on the DIP1 to enable the automatic current reduction.

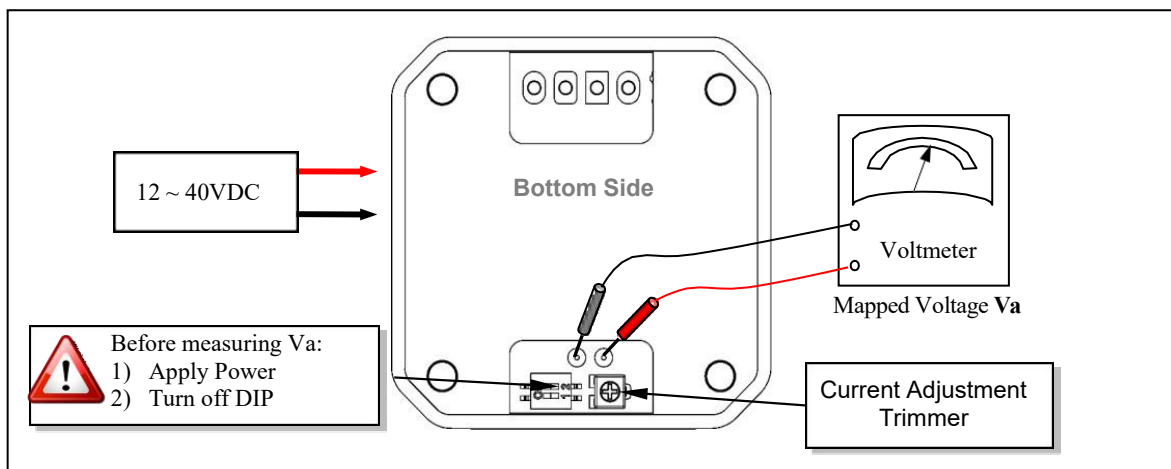

Figure 5: Adjusting the Output Current

5.2 Microstep Resolution

The microstep resolution is set by both DIP switch 1 and DIP switch 2 located at top and bottom side of the driver as shown in following figure. ISD02/04/08 driver can provide microstep control at 100, 200, 400, 800, 1600 step resolutions.

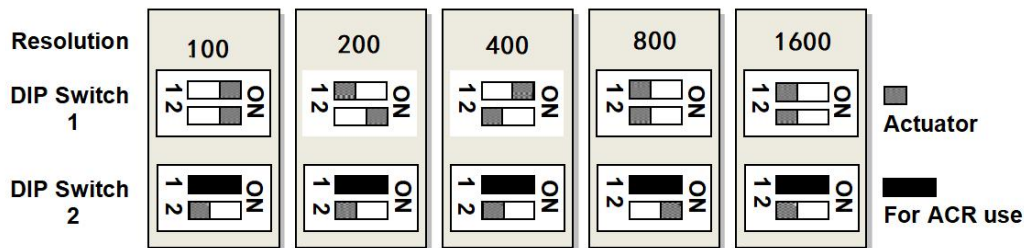

Figure 6: Microstep settings

5.3 Power Supply Selection

ISD02/04/08 drivers accept a wide range input voltage from 12 to 40VDC. (ISD02 takes 10 - 28 VDC) In general, higher supply voltage improves motor performance under high speed situation, but also increases the power loss and temperature raise.

6. Installation

6.1 NEMA 17 Stepper Installation (without adapting flange)

1. Screw mount ISD controller / driver onto the motor
2. Wire the motor leads.

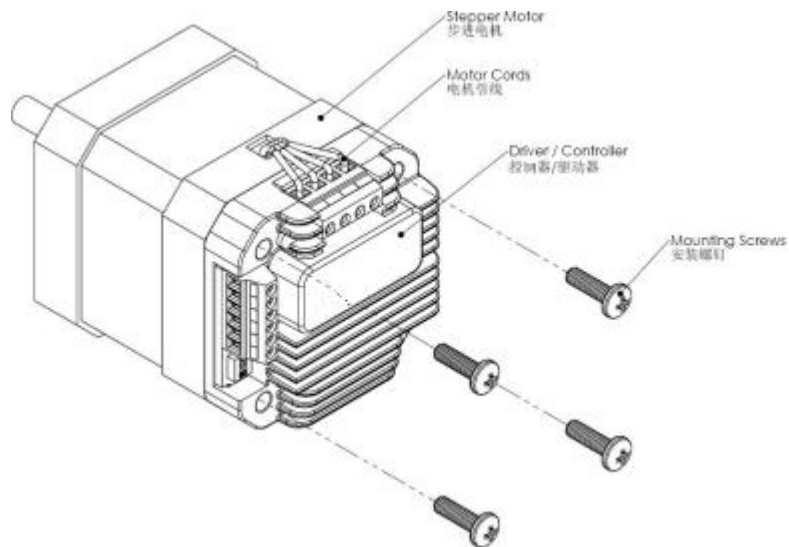

6.2 NEMA 23 and Larger Stepper Installation (with adapting flange)

1. Screw mount the adapting flange onto the motor
2. Screw mount ISD controller / driver onto the adapting flange
3. Wire the motor leads.

