

SPEED - TORQUE CURVE

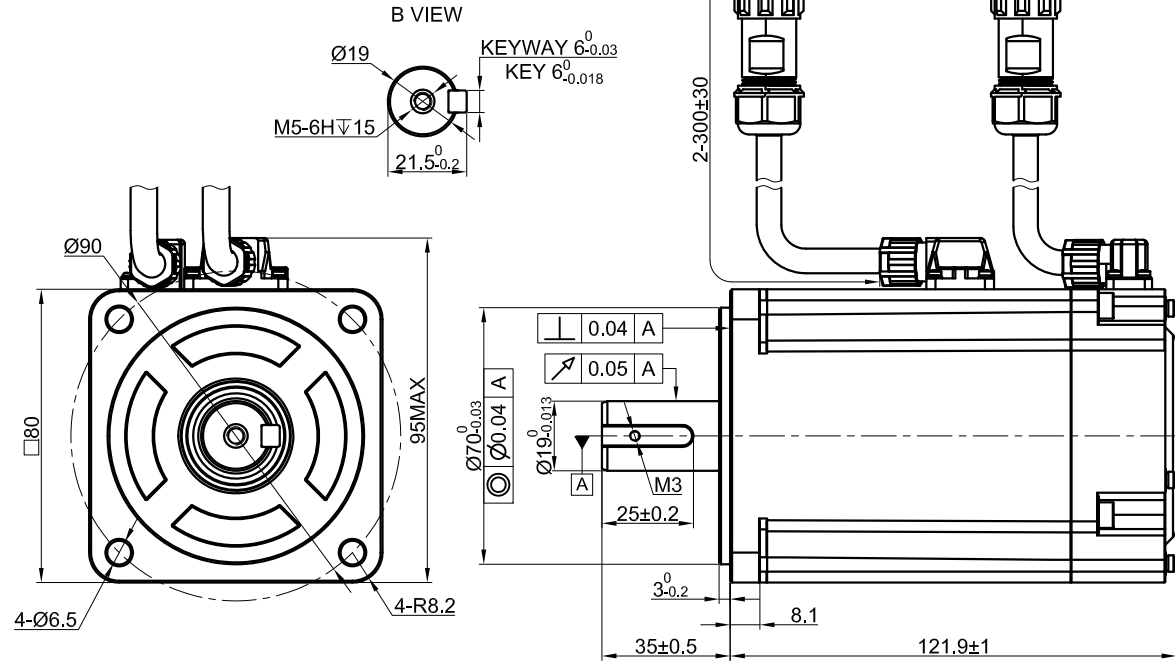
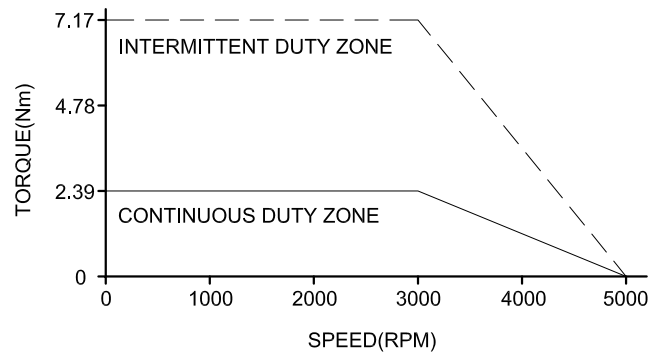

SPECIFICATION	VALUE
RATED VOLTAGE(VAC)	220
RATED POWER(W)	750
RATED TORQUE(Nm)	2.39
PEAK TORQUE(Nm)	7.17
RATED SPEED(RPM)	3000
PEAK SPEED(RPM)	5000
RATED CURRENT(Amp)	4.1
PEAK CURRENT(Amp)	13.4
TORQUE CONST(Nm/Amp)	0.645
BACK EMF CONST(V/KRPM)	39
RESISTANCE( $\Omega$ )	1.7
INDUCTANCE(mH)	8
INERTIA(Kg $\cdot$ m $^2$ $\cdot$ 10 $^{-4}$ )	1.65
POLES	10
ENCODER TYPE	17bit inc
IP RATING	IP65
WEIGHT(KG)	2.7

D	WIRING DETAILS OF POWER CABLE CONNECTOR						
		PIN No.	1	2	3	4	5
	DESCRIPTION	U	W	V	PE	0V	24V
	COLOR	BLU	RED	BLK	YEL/GRE	BLK	RED

C	WIRING DETAILS OF ENCODER CABLE CONNECTOR							
		PIN No.	1	2	3	4	5	6
	DESCRIPTION	PE	5V	0V	SD+	SD-	—	—
	COLOR	SHIELD	WHT	BLK	BLU	PUL	—	—

THE PART NUMBER OF CABLE FOR T6M80-750H2B3-M17S MOTOR	
POWER CABLE	CMBST1M5
ENCODER CABLE	CEST1M5



	APVD		6.10.2022
	CHKD		
2:1	DRN		
SCALE	SIGNATURE		DATE

**AC SERVO MOTOR**  
**T6M80-750H2B3-M17S**